

Over-Voltage Protection IC with Smart Thermal Protection

Features

- Overvoltage Protection up to 28V DC
- VBUS Input Range
 - VBUS: 3.7V to 28V
 - 5A Max Continuous Current Capability
- Adjustable overvoltage threshold from 5V to 22V
- A ultra low R_{DS_ON} 10m Ω (typ.) n-Channel MOSFET
- Built in Soft Start to prevent inrush current
- Ultra-Fast OVP response time(70ns, typ.)
- OTG Functionality from VBUSOUT to VBUSIN
- Smart Thermal Protection
 - Integrated Two Comparators monitoring over-temp.
 - Battery Disconnection output pin
 - Turn off Internal n-MOSFET
 - Over-temp. indicator and internal FET Disable Pin
- Fast VBUSIN Discharge(10k Ω , typ.)
- Powered by VBUSIN or Battery
- 16-Bump, WLCSP 1.63mm x 1.63mm

Applications

- Mobile Handsets and Tablets.
- Wearable Devices

Description

The SM5336, Over-Voltage Protection device, features a very low R_{DS_ON} resistance, 10m Ω (typ.), internal n-MOSFET for USB VBUS line. The n-MOSFET switch ensures safe and right current flow in both battery charging and host mode such as OTG while protecting the internal system circuits from any over voltage condition at VBUSIN pin.

The device also features an adjustable overvoltage threshold with a resistor-divided network. When the VBUS voltage exceeds the overvoltage threshold, the internal n-MOSFET is turned off to prevent any damage for downstream components and enhancing overall system robustness.

The device has Smart Thermal Protection for safe use of Li⁺ battery and to protect the system from damage. There are two comparators for monitoring system Over-temperature.

The SM5336 is available in a 16-bump, 1.63mm x 1.63mm, WLCSP package.

Device Information

Part	Package	Size
SM5336	16 WLCSP	1.63mm x 1.63mm

Simplified Block Diagram

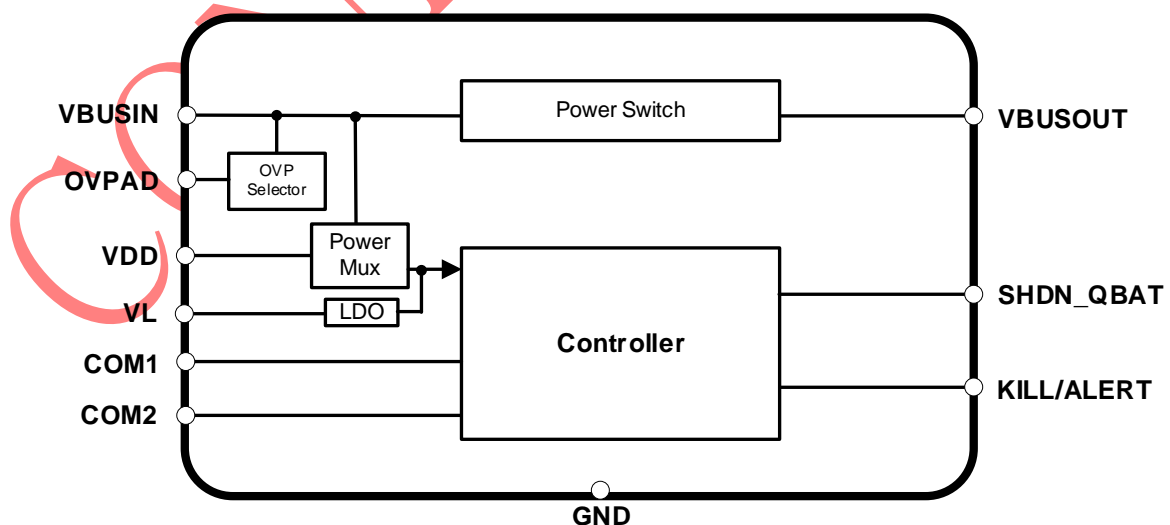

Operational Diagram

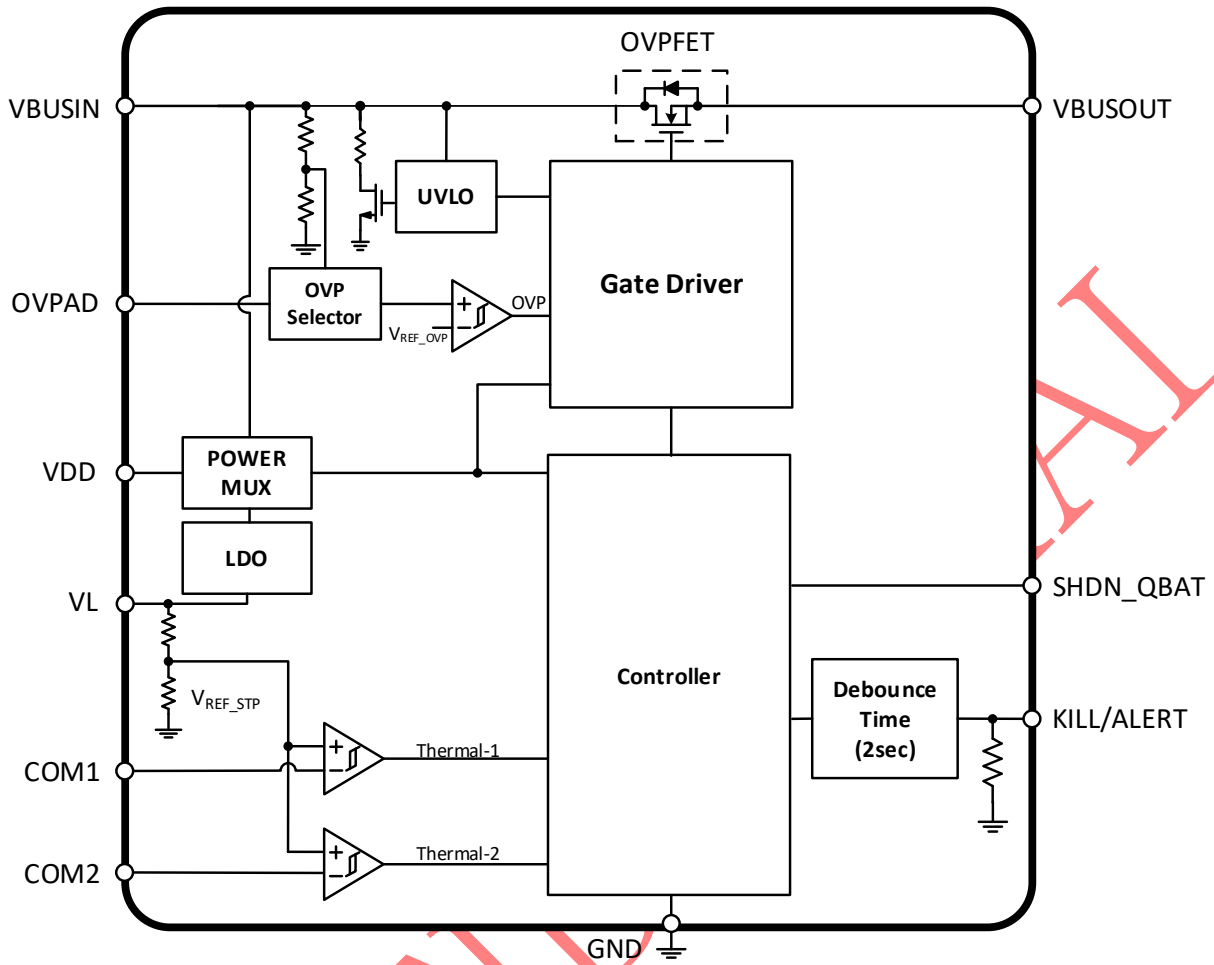

SM5336

Silicon Mitus cannot assume any responsibility for the consequence of use of information furnished nor for any infringement of patents or other rights of third parties which may result from its use. No Circuit patent licenses are implied. Silicon Mitus reserves the right to change the circuitry and specifications without notice at any time. This publication supersedes and replaces all information previously supplied. Silicon Mitus products are not authorized for use as critical components in life support devices or systems without the express written approval of Silicon Mitus.

© 2021 Silicon Mitus, Inc. - Printed in Korea - All Rights Reserved

CONFIDENTIAL